



Read these instructions before commencing installation. Please give these instructions to the owner/occupier after installation to retain for future reference/maintenance.

IP65 IK10 240V~50Hz 10W/14W/20W

These fittings are Class II and do not need an Earth, but Earth provision is provided.

Important Information

It is recommended that these luminaires are installed and fitted by a qualified electrician ensuring the installation complies with current IEE wiring regulations & local building control. These products are designed for connection to a 240V~50Hz supply.

Any faulty, broken or damaged luminaires should be replaced immediately.

KSR will not accept responsibility for any claims arising from a poor installation.

Please Note: The limited warranty shall be deemed null and void in the following circumstances: Failure by the installer, end user or any third party to exercise caution to protect any covered product or part from outside damage, adverse temperature (normal operating ambient temperature 0°C - +30°C), humidity conditions, fluctuations in the electrical system or physical abuse as well as failure related to workmanship in the installation of the products or parts.

Important User Advice

Always switch off mains supply before servicing.

Do not use Megger or similar high voltage instruments. Due to the fact this luminaire contains electronic components that maybe damaged by high test voltages, they must be disconnected from the circuit before testing.

To prevent damage to the driver, do not mix with conventional magnetic ballasts on the same electrical circuit.

At the end of life the luminaire is classed as WEEE under directive 2014/30/EU and should be disposed of in accordance with local legislation.

Installation Procedure

Isolate mains supply before installation.

Remove rim, diffuser and gear tray by turning the rim anti-clockwise.

Remove the rim, diffuser and gear tray from the body by unclipping the support strap.

If you are using the optional chrome rim unclip the white rim from the retaining lugs as per Fig. 1 and install the KSRSF406 rim on to the diffuser/geartray (Do not unscrew LED tray from the diffuser).

Pass supply wires through grommet into the base section, taking care to ensure they are not trapped between the fitting and mounting surface.

Fix base to the wall, ceiling or besa box using adequate fixings with regard to the type of surface.

Ensure incoming cables are protected, re-attach the support strap.

Terminate wiring as per Fig. 2, please note an Earth terminal is only supplied to aid the continuation of the Earth circuit.

Select LED colour and wattage required using the switches on the LED driver Note: Never change the LED colour or wattage with the luminaire powered on as this can damage the luminaire. Fig. 3.

Set Microwave to desired settings, for set up please refer to page overleaf.

Remove the battery cover and connect the emergency battery, replace battery cover (see overleaf).

Install rim, diffuser and gear tray by lining up lugs and twisting clockwise to lock in place.

Turn on the mains supply and test luminaire.

This fitting requires a 24 Hour initial charge period prior to any emergency testing, please see overleaf for testing routine, write on the battery label in permanent ink the date of commissioning.

All results must be recorded and left with the end user.

The battery has a design life of at least 4 years but should be replaced if the duration of operation is less than 3 hours after a 24hr charge time with no interrupted supply.

***Please note: Depending on the amount of fittings on a circuit you may have to upgrade the breaker to a 'C' or 'D' type to avoid nuisance tripping.**

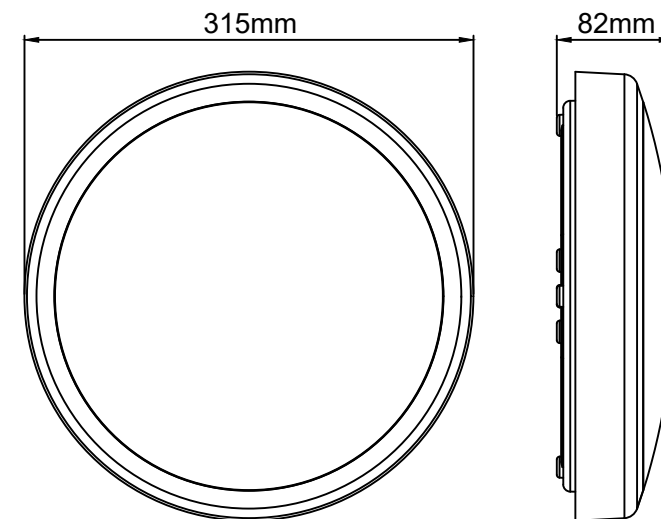

Fig. 1

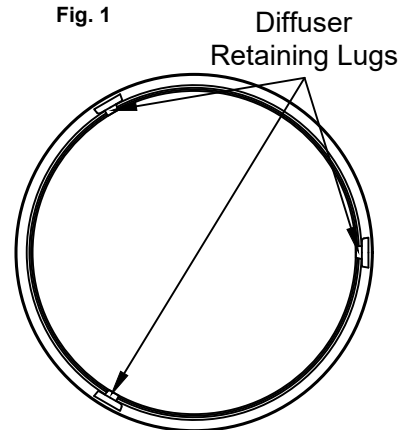

Fig. 3

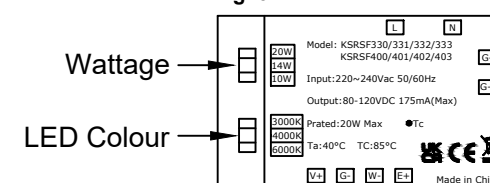
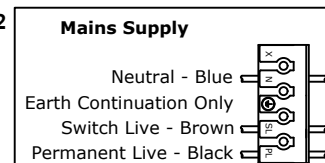

Fig. 2



Lamp Details			
Lamp: LED			
Wattage: 10W, 14W, 20W			
Colour: 3000K, 4000K and 6000K CCT			
CRI: Ra>84			
CCT	Lumen output		
	3000K	4000K	6000K
10W	1067lm	1170lm	1125lm
14W	1341lm	1526lm	1443lm
20W	1719lm	1962lm	1782lm

This product contains a light source of energy efficiency class F

KSR Lighting Aftersales: 023 92 674343

E-mail: aftersales@ksrlighting.com





Read these instructions before commencing installation. Please give these instructions to the owner/occupier after installation to retain for future reference/maintenance.

This Microwave sensor is a motion activated switch, it will turn the light on when movement is detected, then hold the light on for the determined amount of time, after which the light will turn off.

Using the Dip Switches on the sensor, set it up to your preferred Detection area, Hold Time & Daylight level.

Microwave sensors will detect movement through certain materials, if this occurs reduce the detection area until any nuisance triggering stops.

Max Load - 400W (Inductive)(LEDs)

Max Load - 800W (Resistive)

1 - Detection Area

Detection area can be reduced by selecting the combination on the Dip Switches, following the guide as shown here.

	1	2	3	
I	●	●	●	100%
II	○	●	●	75%
III	●	○	●	50%
IV	○	○	●	25%
V	○	○	○	10%

2 - Hold Time

Hold time means the time period you would like the light to remain 'on' once no movement is detected.

	4	5	6	
I	●	●	●	5s
II	○	●	●	30s
III	●	○	●	90s
IV	○	○	●	3min
V	●	●	○	20min
VI	○	○	○	30min

3 - Daylight Sensor

The daylight sensor can be set to bring the light 'on' at specific daylight levels. To have the sensor function in daylight set the Dip Switches to Disable.

	7	8	9	
I	●	●	●	2 lux
II	●	●	○	10 lux
III	○	●	○	25 lux
IV	●	○	○	50 lux
V	○	○	○	Disable

Troubleshooting

Issue	Cause	Solution
The load will not illuminate	Incorrect daylight threshold setting selected	Adjust setting and retest
	Load has failed (driver or LED array)	Replace load
	No mains power detected	Switch on power
The load is permanently illuminated	Continuous movement in the detection area	Check detection area setting
	The lamp (containing sensor) is installed in an area too close to reflective surface, i.e Metal, Glass or Concrete walls.	1. Make sure installation area suitable with at least 30cm space between lamp and surrounding reflective surfaces 2. Reduce Sensitivity (detection area)
The load will not illuminate despite movement	Speed of moving object is not in the range of 0.5-3m/s or the detection radius is too small	Check Detection area setting

The Sensor is designed for installation heights of 3-6m

Recommended Installation heights

For Wall mounting the height is 1.5m
For Ceiling mounting the height is 3m

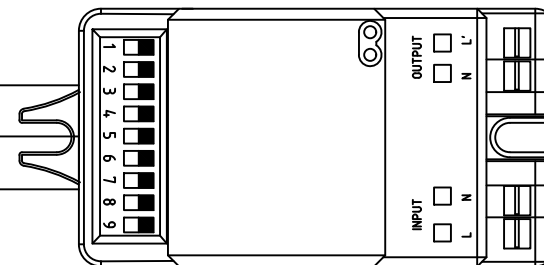



All tests must be undertaken at times of least risk and in accordance with EN 50172:2004 as indicated below:

Daily:
LED charge indicators shall be visually inspected for correct operation.

Monthly:
(in addition to the daily check) If automatic testing devices are used, the results of the short duration tests shall be recorded. Test shall be carried out as follows:

1. Switch the luminaire over to emergency mode to operate from the batteries by simulating a failure of supply to the emergency circuit for a period sufficient to ensure correct luminaire operation.

Note: The period of simulation failure should be sufficient for the purpose of this clause whilst minimising damage to the system components e.g lamps. During this period, all luminaires shall be checked to ensure that they are present, clean and functioning correctly. At the end of this test period, the unswitched supply should be restored and any indicator lamp or device should be checked to ensure that is showing that the supply has been restored.

Annually:
If automatic testing devices are used, the results of the short duration tests shall be recorded. For all other systems the monthly inspection shall be carried out and the following additional tests made:

1. Each luminaire shall be tested monthly as above but for its full duration in accordance with the manufacturer's information.
2. The unswitched supply for the luminaire should be restored and any charge indicator lamp or device should be checked to ensure that it shows the unswitched supply has been restored. The charging arrangements should be checked for proper functioning.
3. The date of the test and its results shall be recorded in the system logbook.

A copy of this report must accompany any emergency luminaire returned to KSR Lighting for any reason.

Battery Maintenance (Removal and Replacement Procedure)

For battery servicing please refer to **Fig 1** showing how to access the battery compartment, please ensure when changing the battery that the circuit is isolated and that the battery replacement is compatible with the product description.

To access the battery compartment simply remove the locking screw with a screwdriver and proceed to remove cover by releasing the holding tab located to the left side of the compartment. When cover is removed disconnect old battery and recycle in accordance with WEEE under directive 2014/30/EU, this should be disposed of in accordance with local legislation. Proceed to connect the new battery by clicking connectors back together and replace battery back into battery housing. With battery in place replace cover onto compartment and fasten in place with locking screw removed earlier. Turn on the mains supply and test luminaire.

Any deviation from the battery specification may result in damage to the emergency circuit or failure to perform under emergency conditions.

Fig. 1

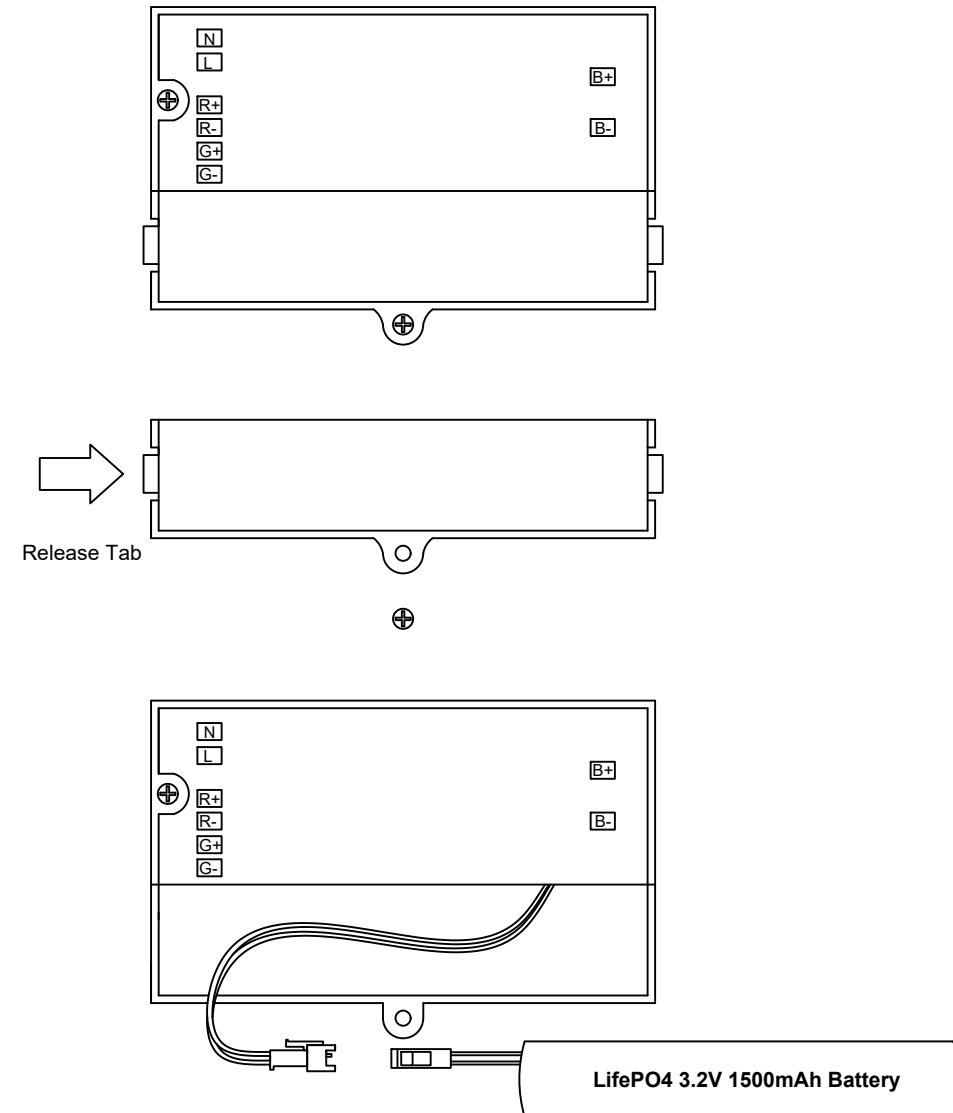

Emergency Lighting Periodic Test Schedule

All emergency lighting should be installed and tested in accordance to EN5266-1:2011. This test schedule should remain onsite and be accessible to the relevant authorities on request.



Em No.	Luminaire Location	Luminaire Type	Start Time	Duration (Mins)	*Pass/Fail	Comments/Actions

Site Address: _____

Test Conducted By: _____

Date of Test Completion: _____

Comments/Actions _____

x √=Pass, X=Fail, N/T=Not Tested, N/A=No Access, U/T=Uncomplete Test