



Available finish:- White/Opal

Read these instructions before commencing installation. Please give these instructions to the owner/occupier after installation to retain for future reference/maintenance.

IP20 IK06

Important Information

It is recommended that these luminaires are installed and fitted by a qualified electrician ensuring the installation complies with current IEE wiring regulations & local building control. These products are designed for connection to a 240V~50Hz supply. Any faulty, broken or damaged luminaires should be replaced immediately. KSR will not accept responsibility for any claims arising from a poor installation. Please Note: The limited warranty shall be deemed null and void in the following circumstances: Failure by the installer, end user or any third party to exercise caution to protect any covered product or part from outside damage, adverse temperature (normal operating ambient temperature (-5 ~ +40°C), humidity conditions, fluctuations in the electrical system or physical abuse as well as failure related to workmanship in the installation of the products or parts.

Important User Advice

Always switch off mains supply before servicing. This luminaire is suitable for indoor use only and should not be fitted to damp or wet surfaces such as freshly plastered or painted ceilings. Do not use Megger or similar high voltage instruments. Due to the fact this luminaire contains electronic components that maybe damaged by high test voltages, they must be disconnected from the circuit before testing. To prevent damage to the driver, do not mix with conventional magnetic ballasts on the same electrical circuit. At the end of life the luminaire is classed as WEEE under directive 2014/30/EU and should be disposed of in accordance with local legislation.

Installation Procedure

Familiarize yourself with the luminaire and ensure the power is turned off before installing the fitting. Loosen the 2 retaining screws located one each end of the body. Remove the diffuser, the diffuser has a lip so working from one end compress the diffuser to release the lip. The diffuser can be left attached to the fitting with the 2 retaining springs or the diffuser can be removed by unclipping the springs. Offer the main body up to the ceiling and mark the fixing points. If using surface conduit ensure the besa boxes are at 600mm centres. Secure the main body in place using suitable fixings for the application, dressing the supply cable though either of the three rear entry points using grommet supplied or via the end caps using suitable cable glands. Connect the mains wiring as per the guide below. If removed re-connect the retaining springs, ensure the retaining screws are not going to foul the casing, then refit the diffuser by clipping back into place (you may find it easier to insert one side first like a hinge then clip the remaining side into place). Ensuring you secure by tightening the retaining screws each end, do not over tighten. Turn on the power and test the luminaire. LEDs are an inductive load so avoid unwanted MCB tripping it may be necessary to up rate your breakers to a C type.

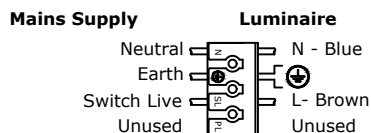

Surface Mount

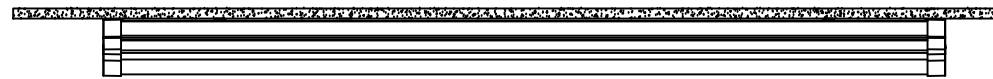

Beza box Mount

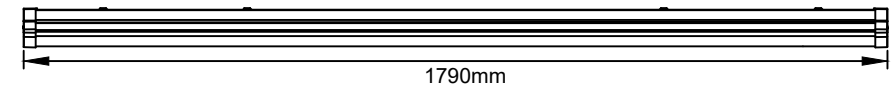
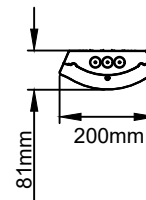
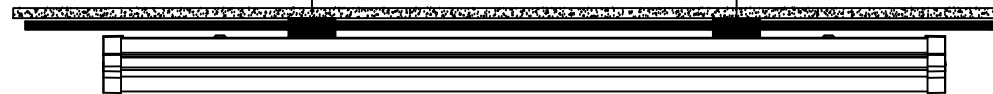

KSR98194

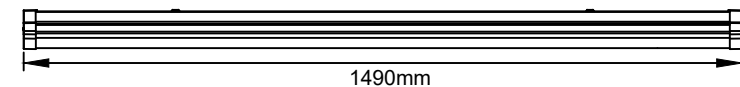
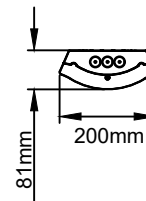

KSR98192

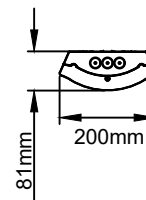

KSR98190

The light source of this luminaire is not replaceable; when the light source reaches its end of life the light source and control gear shall be replaced

This product contains a light source of energy efficiency class E



KSR Lighting Aftersales: 023 92 674343
E-mail: aftersales@ksrlighting.com



Read these instructions before commencing installation. Please give these instructions to the owner/occupier after installation to retain for future reference/maintenance.

IP20 IK06 0.3m 240V~50Hz 20W-65W

These fittings are Class I and must be Earthed

4FT Version

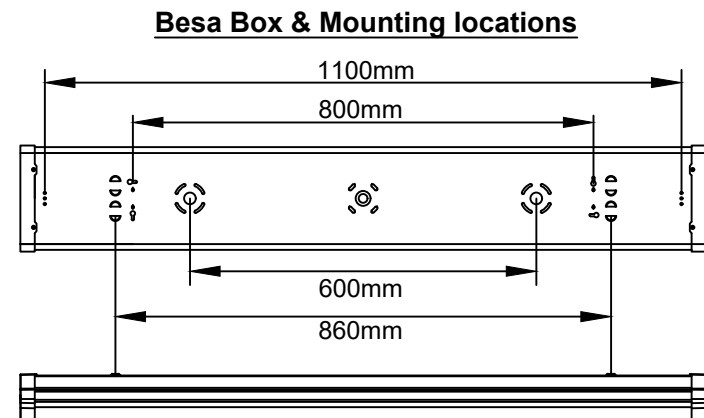

5FT Version

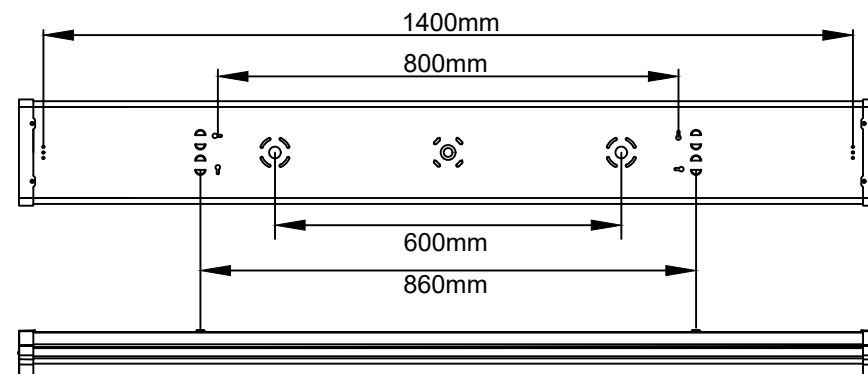

6FT Version

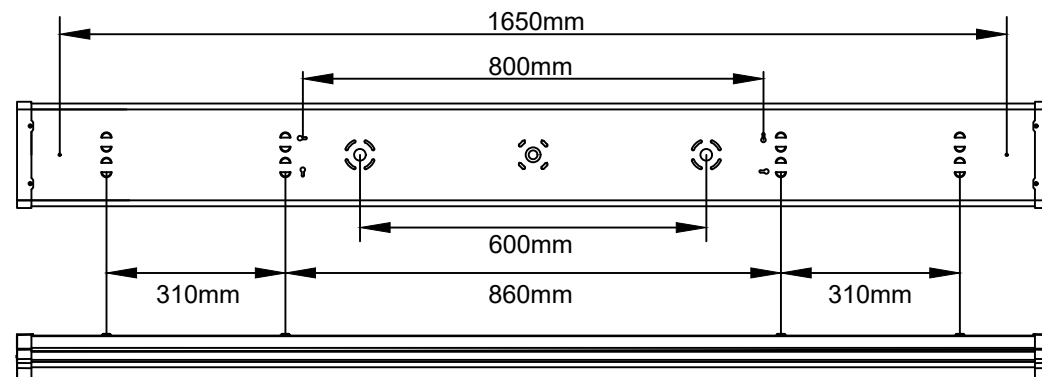

Besa Box & Mounting locations

Product Code	Description	Wattage	Colour	Lumens
KSR98190	Navara X4 Pro - Select 3CCT	20W	3000K	2457
			4000K	2376
			6000K	2465
		38W	3000K	4270
			4000K	4126
			6000K	4378
KSR98192	Navara X5 Pro - Select 3CCT	30W	3000K	3677
			4000K	3573
			6000K	3700
		58W	3000K	6623
			4000K	6480
			6000K	6665
KSR98194	Navara X6 Pro - Select 3CCT	40W	3000K	4700
			4000K	4474
			6000K	4784
		65W	3000K	7280
			4000K	7185
			6000K	7400

Warranty

The LED luminaire comes complete with a 60 month warranty from date of purchase unless otherwise stated. Please note that the emergency packs and batteries come with a 36 month fixed warranty. Should any claim be made against battery failure within the warranty period, full and complete maintenance test reports must be provided.



KSR Lighting Aftersales: 023 92 674343
E-mail: aftersales@ksrlighting.com