



Available finish: Black

Read these instructions before commencing installation. Please give these instructions to the owner/occupier after installation to retain for future reference/maintenance.

IP65 240V~50Hz IK10 18W/30W

These fittings are Class I and must be be Earthed

*This product contains a light source of energy efficiency class F  
The LED light source and Control Gear in this product can be replaced by a professional.*

**Important Information**

It is recommended that these luminaires are installed and fitted by a qualified electrician ensuring the installation complies with current IEE wiring regulations & local building control. These products are designed for connection to a 240V~50Hz supply.

Any faulty, broken or damaged luminaires should be replaced immediately.

KSR will not accept responsibility for any claims arising from a poor installation.

Please Note: The limited warranty shall be deemed null and void in the following circumstances: Failure by the installer, end user or any third party to exercise caution to protect any covered product or part from outside damage, adverse temperature, humidity conditions, fluctuations in the electrical system or physical abuse as well as failure related to workmanship in the installation of the products or parts.

**Important User Advice**

Always switch off mains supply before installing/servicing.

Do not use Megger or similar high voltage instruments. Due to the fact this product contains electronic components that maybe damaged by high test voltages, they must be disconnected from the circuit before testing.

To prevent damage to the driver, do not mix with conventional magnetic ballasts on the same electrical circuit.

KSR recommends a maintenance schedule of washing down with soapy water (no abrasive cleaners) and greasing all screws every 3 months.

At the end of life the luminaire is classed as WEEE under directive 2014/30/EU and should be disposed of in accordance with local legislation

**Installation Procedure**

KSR recommend that you familiarize yourself with the connections.

Safely isolate the mains supply.

Remove the 7 screws that hold the front to the back, retaining the screws.

Open the luminaire, secure the luminaire using suitable fixings into holes 'A' for the substrate.

Using a suitable cable pass the supply cable through the cable gland and terminate the supply cable into the terminal block (Neutral - Blue (N) - Live - Brown (L) & Earth - Green Yellow (⊕)) ensuring a good water tight seal is formed around the cable.

Set the desired colour temp (CCT) via the switch on the LED Driver and the wattage via the dip switch under the driver terminal cover (Set at 30W as standard). Re-fit the front using the retained screws, ensuring the seal is in place and clean. Turn on mains supply and test.

The KSR1192 has a dusk to dawn photocell this will turn the luminaire on at dusk and switch off at dawn.

The fitted dusk to dawn photocell will turn the luminaire on approximately 20-10 lux and switches off at approximately 30-80 lux. It will not detect movement but will continually illuminate the area.

Never install the photocell facing any other artificial or reflected light as this will cause the luminaire to cycle on and off.

Turn on the power and test the luminaire, please note this product is fitted with a Photocell

and is not suitable for use with another unit or photocell sensor as this will damage the sensor/product.

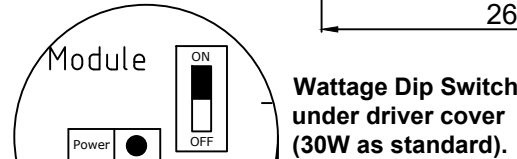
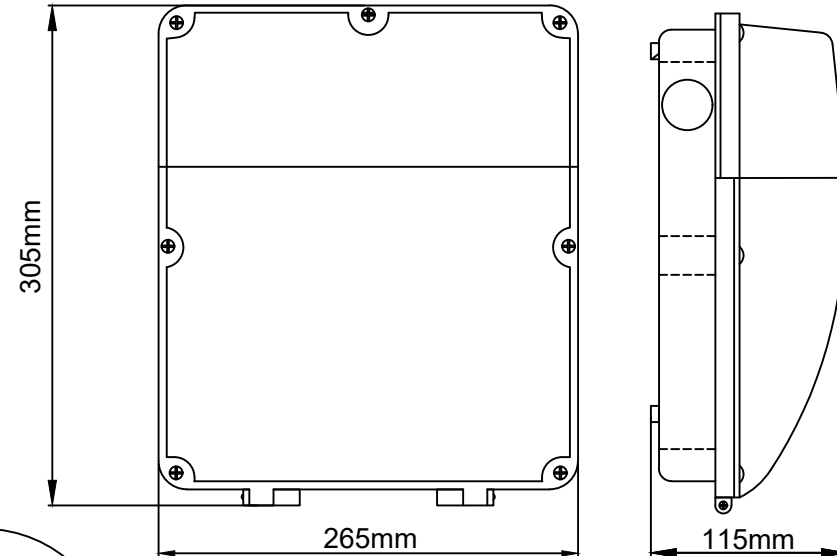

**Wattage Dip Switch under driver cover (30W as standard).**

**CCT Switch**

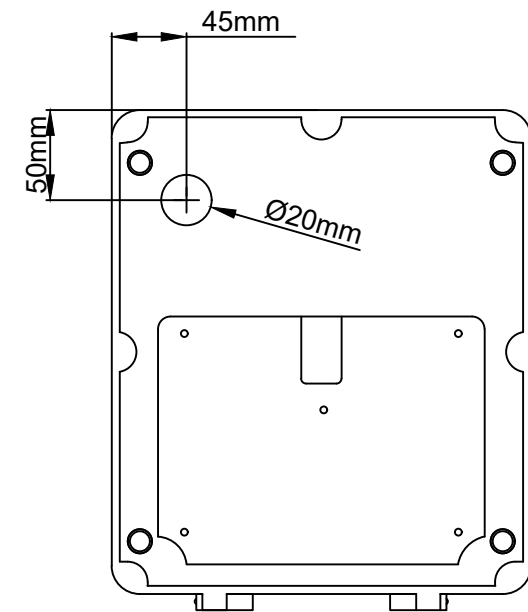
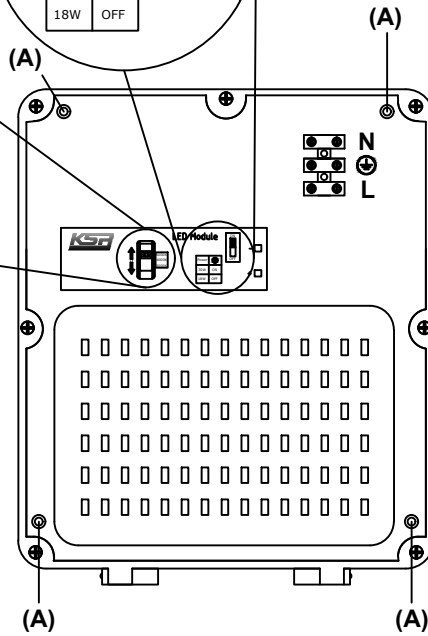
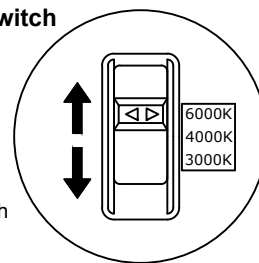

Power	Colour Temperature		
	3000K - CRI 83	4000K - CRI 87	6000K - CRI 84
18W	1500lm	1605lm	1515lm
30W	2475lm	2710lm	2475lm

