



Available Finishes :- Black Base / Opal Diffuser or White Base / Opal Diffuser

Read these instructions before commencing installation. Please give these instructions to the owner/occupier after installation to retain for future reference/maintenance.

IP65 IK10 240V~50Hz 10W/14W/20W

These fittings are Class II and do not need an Earth, but Earth provision is provided.

Important Information

It is recommended that these luminaires are installed and fitted by a qualified electrician ensuring the installation complies with current IEE wiring regulations & local building control. These products are designed for connection to a 240V~50Hz supply. Any faulty, broken or damaged luminaires should be replaced immediately. KSR will not accept responsibility for any claims arising from a poor installation. Please Note: The limited warranty shall be deemed null and void in the following circumstances: Failure by the installer, end user or any third party to exercise caution to protect any covered product or part from outside damage, adverse temperature (normal operating ambient temperature 0°C - +30°C), humidity conditions, fluctuations in the electrical system or physical abuse as well as failure related to workmanship in the installation of the products or parts.

Important User Advice

Always switch off mains supply before servicing. Do not use Megger or similar high voltage instruments. Due to the fact this luminaire contains electronic components that maybe damaged by high test voltages, they must be disconnected from the circuit before testing. To prevent damage to the driver, do not mix with conventional magnetic ballasts on the same electrical circuit. At the end of life the luminaire is classed as WEEE under directive 2014/30/EU and should be disposed of in accordance with local legislation.

Installation Procedure

Isolate mains supply before installation. Unscrew and retain the four screws and remove the diffuser. Unlock the LED tray by turning the retaining lug anti-clockwise as shown in Fig.1 and lift the hinged tray to gain access to the wiring terminals. Pass intended supply cable through the grommet. Ensure the fixing surface is flat and even. Fix base to the wall, ceiling or besa box using adequate fixings with regard to the type of surface. Ensure incoming cables are protected. Terminate wiring as per Fig. 2, please note an Earth terminal is only supplied to aid the continuation of the Earth circuit. Select LED colour and wattage required using the switches on the LED driver Note: Never change the LED colour or wattage with the luminaire powered on as this can damage the luminaire. Fig. 3. To set Photocell adjust the Lux level required via the adjuster (anti-clockwise = lowest, clockwise = highest) and to test simply cover photocell when powered on in daylight and wait for the luminaire to Light up. Proceed to Re-secure the LED tray by turning the retaining lug clockwise. Make sure the seal is in place in the diffuser and undamaged. Replace the diffuser re-secure using the four retained screws. Turn on the mains supply and test luminaire. If using an optional rim clip the rim over the fitting.

This fitting requires a 24 Hour initial charge period prior to any emergency testing, please see overleaf for testing routine, write on the battery label in permanent ink the date of commissioning. All results must be recorded and left with the end user. The battery has a design life of at least 4 years but should be replaced if the duration of operation is less than 3 hours after a 24hr charge time with no interrupted supply.

Location- Ensure the Photocell is not located in a position where the artificial lighting will illuminate it, this may cause the Photocell to switch off.

Photocell Specification:

Mains Input - 220~240V AC 50/60Hz
Lux Setting - 5-50 Lux (Adjustable)
Rated Load - 10 Amp Maximum
Material Thickness: 0-7.5mm
Parasitic Power - 0.5W

Fig. 2

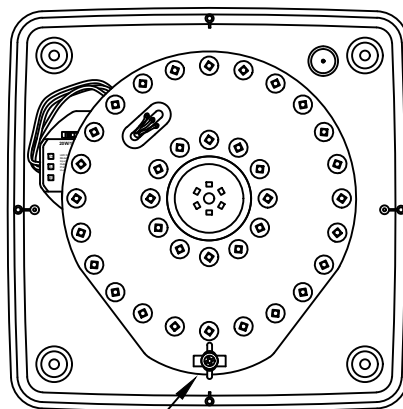
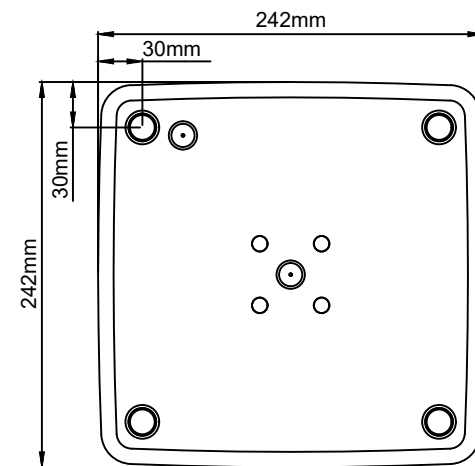
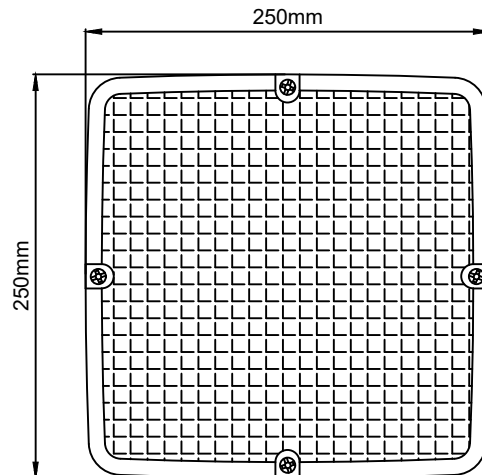
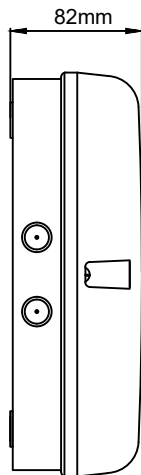
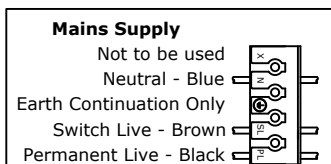
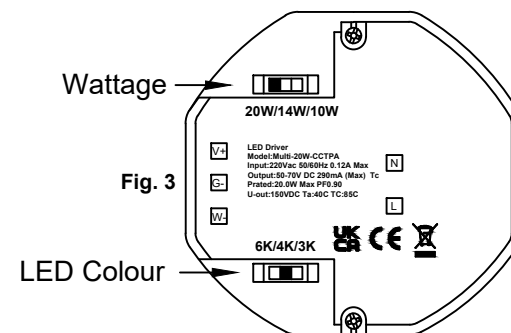

Fig. 1
Gear Tray Retaining Lug



Lamp Details

Lamp: LED
Wattage: 10W, 14W, 20W
Colour: 3000K, 4000K and 6000K CCT
CRI: Ra>81

CCT	Lumen output		
	3000K	4000K	6000K
10W	870lm	945lm	920lm
14W	1240lm	1350lm	1305lm
20W	1750lm	1955lm	1885lm

This product contains a light source of energy efficiency class F. The LED light source and Control Gear in this product is replaceable by a professional.





All tests must be undertaken at times of least risk and in accordance with EN 50172:2004 as indicated below:

Daily:

LED charge indicators shall be visually inspected for correct operation.

Monthly:

(in addition to the daily check) If automatic testing devices are used, the results of the short duration tests shall be recorded.

Test shall be carried out as follows:

1. Switch the luminaire over to emergency mode to operate from the batteries by simulating a failure of supply to the emergency circuit for a period sufficient to ensure correct luminaire operation.

Note: The period of simulation failure should be sufficient for the purpose of this clause whilst minimising damage to the system components e.g lamps. During this period, all luminaires shall be checked to ensure that they are present, clean and functioning correctly. At the end of this test period, the unswitched supply should be restored and any indicator lamp or device should be checked to ensure that it is showing that the supply has been restored.

Annually:

If automatic testing devices are used, the results of the short duration tests shall be recorded. For all other systems the monthly inspection shall be carried out and the following additional tests made:

1. Each luminaire shall be tested monthly as above but for its full duration in accordance with the manufacturer's information.
2. The unswitched supply for the luminaire should be restored and any charge indicator lamp or device should be checked to ensure that it shows the unswitched supply has been restored. The charging arrangements should be checked for proper functioning.
3. The date of the test and its results shall be recorded in the system logbook.

A copy of this report must accompany any emergency luminaire returned to KSR Lighting for any reason.



